FUEL SYSTEM

ELECTRONIC CONTROL TYPE CARBURETOR

CONTENTS

| | |
|---------------------------------|----------|
| 1. SPECIFICATIONS | 13C-1- 1 |
| GENERAL SPECIFICATIONS | 13C-1- 1 |
| CARBURETOR SPECIFICATIONS | 13C-1- 2 |
| SERVICE SPECIFICATIONS | 13C-1- 3 |
| TORQUE SPECIFICATIONS | 13C-1- 3 |
| 2. FUEL PUMP | 13C-2- 1 |
| 3. CARBURETOR ASSEMBLY | 13C-3- 1 |
| 4. CARBURETOR | 13C-4- 1 |

1. SPECIFICATIONS

GENERAL SPECIFICATIONS – 1990 MODELS

| Vehicle model | Engine | Trans- mission | Carburetor | | | | | Cold mixture heater | |
|---------------|------------------------------------|-------------------|--------------------|----------------|-----------------------------------|--------------|-------|---------------------------|---|
| | | | Identification No. | Choke type | No. of solenoid | Tamper proof | | | |
| | | | | | | MAS | Choke | | |
| EC | Colt/ Lancer (C51A, C61A) | 4G13 | M/T | 30-32DIDEF-334 | Automatic (Electrical type) | 2 | A3 | X | X |
| | | | | 30-32DIDEF-335 | | | SB | X | |
| | | | | 30-32DIDEF-336 | | | A3 | X | |
| | Lancer station wagon-4WD | 4G37 | M/T | 32-35DIDEF-364 | Automatic (Electrical type) | 2 | A3 | X | X |
| | | | | 32-35DIDEF-366 | | | SB | X | |
| | Pajero | G54B | M/T | 32-35DIDEF-369 | Automatic (Electrical type) | 2 | A3 | X | - |
| | | | | 32-35DIDEF-450 | | | SB | X | |
| | L300 | 4G63 | M/T | 32-35DIDEF-367 | Automatic (Electrical type) | 2 | A3 | X | - |
| | | | | 32-35DIDEF-368 | | | SB | X | |

GENERAL SPECIFICATIONS – 1991 MODELS

| Vehicle model | Engine | Trans- mission | Carburetor | | | | | Cold mixture heater | |
|---------------|------------------------------------|-------------------|--------------------|----------------|-----------------------------------|--------------|-------|---------------------------|---|
| | | | Identification No. | Choke type | No. of solenoid | Tamper proof | | | |
| | | | | | | MAS | Choke | | |
| EC | Colt/ Lancer (C51A, C61A) | 4G13 | M/T | 30-35DIDEF-50 | Automatic (Electrical type) | 2 | A3 | X | X |
| | | | | 30-35DIDEF-51 | | | SB | X | |
| | L200-4WD | G54B | M/T | 32-35DIDEF-451 | Automatic (Electrical type) | 2 | A3 | X | - |
| | L300 | 4G63 | M/T | 32-35DIDEF-367 | Automatic (Electrical type) | 2 | A3 | X | - |
| | | | | 32-35DIDEF-368 | | | SB | X | |

GENERAL SPECIFICATIONS – 1992 MODELS

| Vehicle model | Engine | Trans- mission | Carburetor | | | | | Cold mixture heater | |
|---------------------|------------------------------------|-------------------|--------------------|----------------|-----------------------------------|--------------|-------|---------------------------|---|
| | | | Identification No. | Choke type | No. of solenoid | Tamper proof | | | |
| | | | | | | MAS | Choke | | |
| EC | L200-4WD | G54B | M/T | 32-35DIDEF-451 | Automatic (Electrical type) | 2 | A3 | X | X |
| | L300 | 4G63 | M/T | 32-35DIDEF-367 | Automatic (Electrical type) | 2 | A3 | X | - |
| | | | | 32-35DIDEF-368 | | | SB | X | |
| EXP Hong Kong | Colt/ Lancer (CA1A, CB1A) | 4G13 | M/T | 30-35DIDTF-20 | Automatic (Wax type) | 2 | - | - | - |
| | | | A/T | 30-35DIDTF-21 | Automatic (Wax type) | 2 | - | - | - |

NOTES

M/T: Manual Transmission
 A/T: Automatic transmission
 4WD: Four Wheel Drive
 X: Applicable
 -: Not Applicable

MAS Tamper proof



A3 SB

GENERAL SPECIFICATIONS - 1993 MODELS

| Vehicle model | Engine | Trans- mission | Carburetor | | | | | | Cold mixture heater |
|---------------|----------|-------------------|--------------------|----------------|-----------------------------------|--------------|-------|---|---------------------------|
| | | | Identification No. | Choke type | No. of solenoid | Tamper proof | | | |
| | | | | | | MAS | Choke | | |
| EC | L200-4WD | G54B | M/T | 32-35DIDEF-455 | Automatic (Electrical type) | 2 | A3 | X | - |
| | L300 | 4G63 | M/T | 32-35DIDEF-453 | Automatic (Electrical type) | 2 | A3 | X | - |
| | | | | 32-35DIDEF-454 | | | SB | X | |



GENERAL SPECIFICATIONS - 1994 MODELS

| Vehicle model | Engine | Trans- mission | Carburetor | | | | | | Cold mixture heater |
|---------------------|--------------------------------------|-------------------|--------------------|----------------|-----------------------------------|--------------|-------|---|---------------------------|
| | | | Identification No. | Choke type | No. of solenoid | Tamper proof | | | |
| | | | | | | MAS | Choke | | |
| EC | L200-4WD | G54B | M/T | 32-35DIDEF-455 | Automatic (Electrical type) | 2 | A3 | X | - |
| | L300 | 4G63 | M/T | 32-35DIDEF-453 | Automatic (Electrical type) | 2 | A3 | X | - |
| | | | | 32-35DIDEF-454 | | | SB | X | |
| EXP Hong Kong | Lancer (CB1A) | 4G13 | M/T | 30-35DIDTF-50 | Automatic (Wax type) | 2 | - | - | - |
| | | | A/T | 30-35DIDTF-51 | | | - | - | - |
| | Lancer Station Wagon (CB1W) | 4G13 | M/T | 30-35DIDTF-50 | Automatic (Wax type) | 2 | - | - | - |

NOTES

M/T: Manual Transmission
A/T: Automatic Transmission
4WD: Four Wheel Drive
X: Applicable
-: Not Applicable

MAS Tamper proof

 
A3 SB

GENERAL SPECIFICATIONS – 1995 MODELS

| Vehicle model | Engine | Trans- mission | Carburetor | | | | | | Cold mixture heater | |
|---------------------|--------------------------------------|-------------------|--------------------|-------------------------|-----------------------------------|--------------|-------|---|---------------------------|---|
| | | | Identification No. | Choke type | No. of solenoid | Tamper proof | | | | |
| | | | | | | MAS | Choke | | | |
| EC | L200-4WD | G54B | M/T | 32-35DIDEF-455 | Automatic (Electrical type) | 2 | A3 | X | - | |
| | L300 | 4G63 | M/T | 32-35DIDEF-459 | Automatic (Electrical type) | 2 | SB | X | - | |
| | | | | 32-35DIDEF-472 | | | | | | |
| | L400 | 4G63 | M/T | 32-35DIDEF-458 | Automatic (Electrical type) | 2 | SB | X | - | |
| 32-35DIDEF-471 | | | | | | | | | | |
| EXP Hong Kong | Lancer (CB1A) | 4G13 | M/T | 30-35DIDTF-66 | Automatic (Wax type) | 3 | - | - | - | |
| | | | A/T | 30-35DIDTF-67 | | | | | | |
| | Lancer Station Wagon (CB1W) | 4G13 | M/T | 30-35DIDTF-66 | Automatic (Wax type) | 3 | - | - | - | |
| | L300 | 4G92 | M/T | 32-35DIDTF-484 | Automatic (Wax type) | 2 | A3 | - | - | - |
| | | | | 32-35DIDTF-485 | | | | | | |
| L400 | 4G63 | M/T | 32-35DIDTF-489 | Automatic (Wax type) | 2 | A3 | X | - | | |

GENERAL SPECIFICATIONS – 1996, 1997 MODELS

| Vehicle model | Engine | Trans- mission | Carburetor | | | | | | Cold mixture heater |
|---------------------|--------|-------------------|--------------------|----------------|-------------------------|--------------|-------|---|---------------------------|
| | | | Identification No. | Choke type | No. of solenoid | Tamper proof | | | |
| | | | | | | MAS | Choke | | |
| EXP Hong Kong | L300 | 4G92 | M/T | 32-35DIDTF-484 | Automatic (Wax type) | 2 | A3 | - | - |
| | | | | 32-35DIDTF-485 | | | | | |
| | L400 | 4G63 | M/T | 32-35DIDTF-489 | Automatic (Wax type) | 2 | A3 | X | - |

GENERAL SPECIFICATIONS – 1998 MODELS

| Vehicle model | Engine | Trans- mission | Carburetor | | | | | | Cold mixture heater |
|---------------------|--------------------------------------|-------------------|--------------------|----------------|-------------------------|--------------|-------|---|---------------------------|
| | | | Identification No. | Choke type | No. of solenoid | Tamper proof | | | |
| | | | | | | MAS | Choke | | |
| EXP Hong Kong | Lancer Station Wagon (CB1W) | 4G13 | M/T | 30-35DIDTF-66 | Automatic (Wax type) | 3 | - | - | - |
| | L300 | 4G92 | M/T | 32-35DIDTF-485 | Automatic (Wax type) | 2 | A3 | - | - |

NOTES

M/T: Manual Transmission
A/T: Automatic Transmission
4WD: Four Wheel Drive
X: Applicable
-: Not Applicable

MAS Tamper proof



A3 SB

CARBURETOR SPECIFICATIONS

| Identification No. | Throttle bore | Main jet | Pilot jet | Enrichment jet | T / O | D / P | T P S | B V V | M C V | A A P |
|--------------------|---------------|-----------|-----------|----------------|-------|-------|-------|-------|-------|-------|
| | mm (in.) | Primary | Primary | | | | | | | |
| | Secondary | Secondary | Secondary | | | | | | | |
| 30-32DIDEF-334 | 30 (1.181) | #92.5 | #48.8 | #40 | - | X | X | X | X | - |
| | 32 (1.260) | #145 | #70 | | | | | | | |
| 30-32DIDEF-335 | 30 (1.181) | #92.5 | #48.8 | #40 | - | X | X | X | X | - |
| | 32 (1.260) | #145 | #70 | | | | | | | |
| 30-32DIDEF-336 | 30 (1.181) | #92.5 | #48.8 | #40 | - | X | X | X | X | - |
| | 32 (1.260) | #145 | #70 | | | | | | | |
| 30-35DIDEF-50 | 30 (1.181) | #81.3 | #47.5 | #40 | X | X | X | X | X | - |
| | 35 (1.378) | #145 | #75 | | | | | | | |
| 30-35DIDEF-51 | 30 (1.181) | #81.3 | #47.5 | #40 | X | X | X | X | X | - |
| | 35 (1.378) | #145 | #75 | | | | | | | |
| 32-35DIDEF-364 | 32 (1.260) | #97.5 | #41.3 | #50 | X | X | X | X | X | - |
| | 35 (1.378) | #152.5 | #60 | | | | | | | |
| 32-35DIDEF-366 | 32 (1.260) | #97.5 | #41.3 | #50 | X | X | X | X | X | - |
| | 35 (1.378) | #152.5 | #60 | | | | | | | |
| 32-35DIDEF-367 | 32 (1.260) | #100 | #50 | #55 | - | X | X | X | X | X |
| | 35 (1.378) | #167.5 | #60 | | | | | | | |
| 32-35DIDEF-368 | 32 (1.260) | #100 | #50 | #55 | - | X | X | X | X | X |
| | 35 (1.378) | #167.5 | #60 | | | | | | | |
| 32-35DIDEF-369 | 32 (1.260) | #107.5 | #55 | #65 | X | X | X | X | X | X |
| | 35 (1.378) | #190 | #70 | | | | | | | |
| 32-35DIDEF-450 | 32 (1.260) | #107.5 | #55 | #65 | X | X | X | X | X | X |
| | 35 (1.378) | #190 | #70 | | | | | | | |
| 32-35DIDEF-451 | 32 (1.260) | #107.5 | #55 | #65 | X | X | X | X | X | X |
| | 35 (1.378) | #190 | #70 | | | | | | | |
| 32-35DIDEF-453 | 32 (1.260) | #100 | #50 | #55 | X | X | X | X | X | X |
| | 35 (1.378) | #167.5 | #60 | | | | | | | |
| 32-35DIDEF-454 | 32 (1.260) | #100 | #50 | #55 | X | X | X | X | X | X |
| | 35 (1.378) | #167.5 | #60 | | | | | | | |
| 32-35DIDEF-455 | 32 (1.260) | #107.5 | #55 | #65 | X | X | X | X | X | X |
| | 35 (1.378) | #190 | #70 | | | | | | | |

| Identification No. | Throttle bore | Main jet | Pilot jet | Enrichment jet | T / O | D / P | T P S | B V V | M C V | A A P | |
|--------------------|---------------|-----------|-----------|----------------|-------|-------|-------|-------|-------|-------|-----------|
| | mm (in.) | Primary | Primary | | | | | | | | Primary |
| | Secondary | Secondary | Secondary | | | | | | | | Secondary |
| 32-35DIDEF-458 | 32 (1.260) | #103.8 | #48.8 | #60 | - | - | X | X | X | X | |
| | 35 (1.378) | #165 | #70 | | | | | | | | |
| 32-35DIDEF-459 | 32 (1.260) | #103.8 | #52.5 | #70 | - | - | X | X | X | X | |
| | 35 (1.378) | #165 | #70 | | | | | | | | |
| 32-35DIDEF-471 | 32 (1.260) | #103.8 | #48.8 | #60 | X | - | X | X | X | X | |
| | 35 (1.378) | #165 | #70 | | | | | | | | |
| 32-35DIDEF-472 | 32 (1.260) | #103.8 | #52.5 | #70 | X | - | X | X | X | X | |
| | 35 (1.378) | #165 | #70 | | | | | | | | |
| 30-35DIDTF-20 | 30 (1.181) | #85 | #46.3 | #45 | X | X | X | - | - | X | |
| | 35 (1.378) | #150 | #75 | | | | | | | | |
| 30-35DIDTF-21 | 30 (1.181) | #85 | #46.3 | #45 | X | - | X | - | X | X | |
| | 35 (1.378) | #150 | #75 | | | | | | | | |
| 30-35DIDTF-50 | 30 (1.181) | #85 | #46.3 | #45 | X | X | X | - | - | X | |
| | 35 (1.378) | #150 | #75 | | | | | | | | |
| 30-35DIDTF-51 | 30 (1.181) | #85 | #46.3 | #45 | X | - | X | - | X | X | |
| | 35 (1.378) | #150 | #75 | | | | | | | | |
| 30-35DIDTF-66 | 30 (1.181) | #85 | #46.3 | #45 | X | X | X | - | - | X | |
| | 35 (1.378) | #150 | #75 | | | | | | | | |
| 30-35DIDTF-67 | 30 (1.181) | #85 | #46.3 | #45 | X | - | X | - | X | X | |
| | 35 (1.378) | #150 | #75 | | | | | | | | |
| 30-35DIDTF-484 | 32 (1.260) | #96.3 | #50 | #55 | X | - | X | X | - | X | |
| | 35 (1.378) | #182.5 | #70 | | | | | | | | |
| 30-35DIDTF-485 | 32 (1.260) | #96.3 | #50 | #55 | - | - | X | X | - | X | |
| | 35 (1.378) | #182.5 | #70 | | | | | | | | |
| 30-35DIDTF-489 | 32 (1.260) | #107.5 | #52.5 | #50 | - | - | X | X | - | X | |
| | 35 (1.378) | #165 | #70 | | | | | | | | |

NOTES

T/O: Throttle opener

D/P: Dash pot

TPS: Throttle position sensor

BW: Bowl vent valve

MCV: Mixture control valve

AAP: Auxiliary Accelerator Pump

X: Applicable

-: Not applicable

Intentionally blank

SERVICE SPECIFICATIONS

mm (in.)

| | | Standard |
|------------------------------------|--------------------|---|
| Cold mixture heater resistance | | Approx. 1 Ω |
| [at 20°C (68°F)] | | |
| Feedback solenoid valve resistance | | 54 – 66 Ω |
| [at 20°C (68°F)] | | |
| Choke breaker opening | First stage | 32-35DIDEF-364, 366: 1.8 – 2.0 (0.071 - 0.079) |
| | Second stage | 30-32DIDEF-334, 335, 336 30-35DIDEF-50, 51 30-35DIDTF-20, 21, 50, 51, 66, 67 32-35DIDEF-453, 454: 1.4 – 1.6 (0.055 – 0.063) 32-35DIDEF-369, 450, 451, 455: 2.3 – 2.5 (0.091 – 0.098) 32-35DIDEF-367, 368: 2.0 – 2.2 (0.079 – 0.087) 32-35DIDEF-458, 459, 471, 472: 1.9 – 2.1 (0.075 – 0.083) 32-35DIDTF-484, 485, 489: 2.1 – 2.3 (0.083 – 0.091) 30-32DIDEF-334, 335, 336 30-35DIDEF-50, 51 32-35DIDEF-364, 366, 367, 368, 453, 454, 458, 459, 471, 472: 2.9 – 3.1 (0.114 – 0.122) 32-35DIDEF-369, 450, 451, 455: 3.0 – 3.2 (0.118 – 0.126) |

TORQUE SPECIFICATIONS

| | Nm | Torque | |
|--|-----|--------|---------|
| | | kgm | ft.lbs. |
| Carburetor attaching bolt | 18 | 1.8 | 12.5 |
| Throttle position sensor attaching screw | 3.5 | 0.35 | 2.5 |

NOTES

2. FUEL PUMP

REMOVAL AND INSTALLATION – 4G1 <8 valve engine>

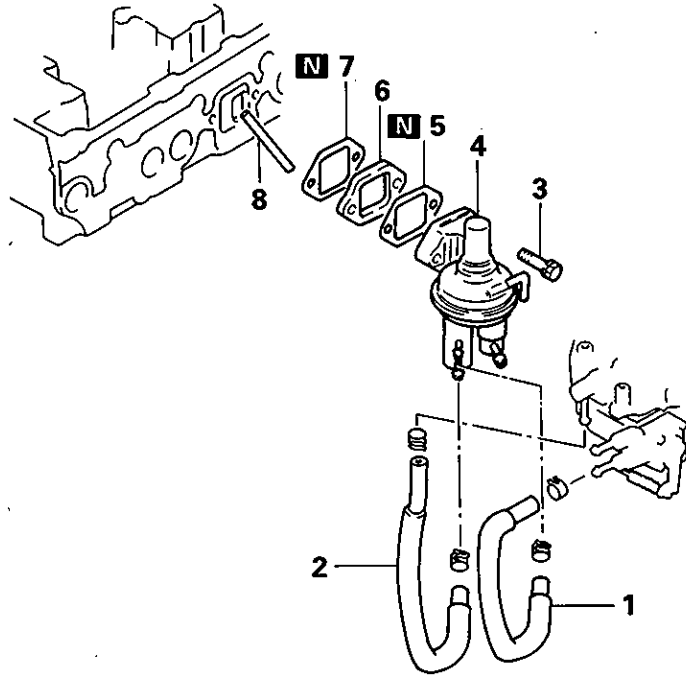

Removal steps

1. Return hose
2. Outlet hose
3. Bolt
- ◆A◆ ◆B◆ 4. Fuel pump
5. Gasket
6. Insulator
7. Gasket
- ◆A◆ 8. Push rod

1FU281

REMOVAL AND INSTALLATION – 4G1 <12 valve engine>

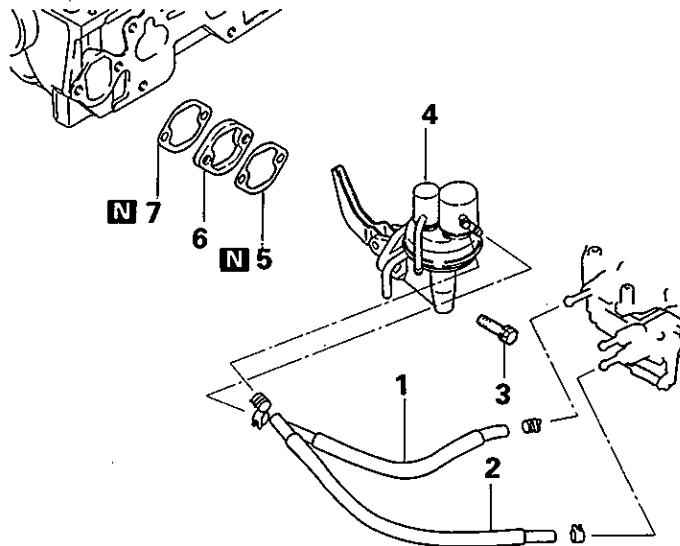

Removal steps

1. Return hose
2. Outlet hose
3. Bolt
- ◆A◆ ◆B◆ 4. Fuel pump
5. Gasket
6. Insulator
7. Gasket

1FU0550

REMOVAL AND INSTALLATION – 4G5

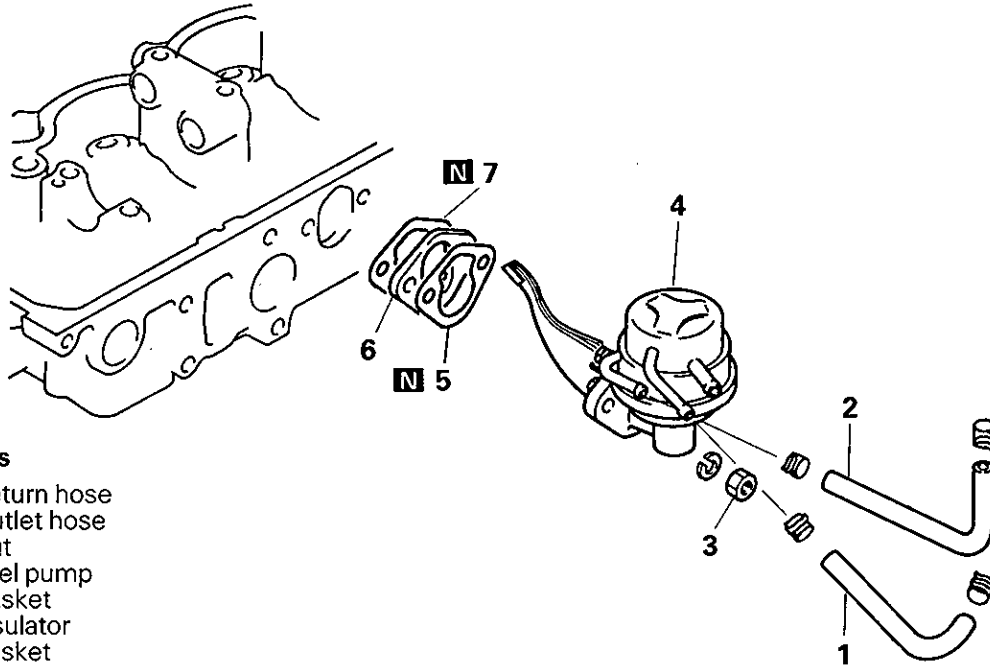

Removal steps

- 1. Return hose
- 2. Outlet hose
- 3. Nut
- ◊C◊ ◊A◊ 4. Fuel pump
- 5. Gasket
- 6. Insulator
- 7. Gasket

5FU005

REMOVAL AND INSTALLATION – 4G6

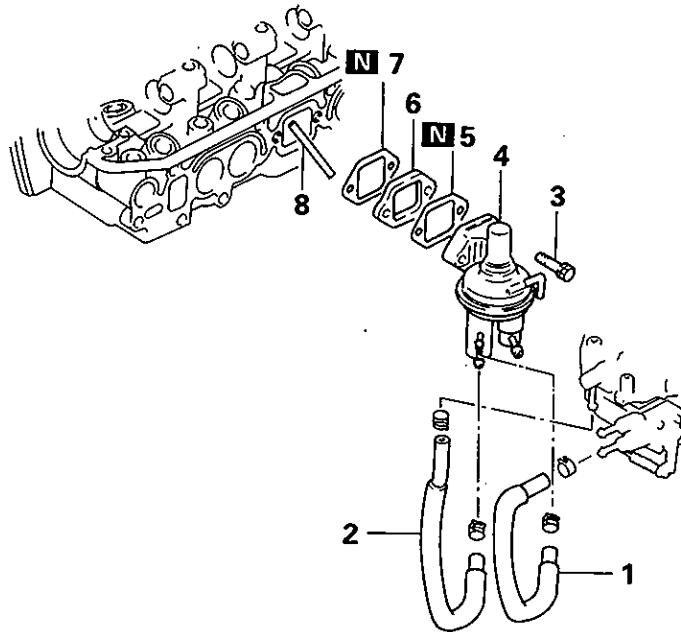

Removal steps

- 1. Return hose
- 2. Outlet hose
- 3. Bolt
- ◊A◊ ◊B◊ 4. Fuel pump
- 5. Gasket
- 6. Insulator
- 7. Gasket
- ◊A◊ 8. Push rod

6FU366

SERVICE POINTS OF REMOVAL, INSPECTION, INSTALLATION

Refer to GROUP 13A – FUEL PUMP and Group 13B – FUEL PUMP (4G1 12 valve engine)

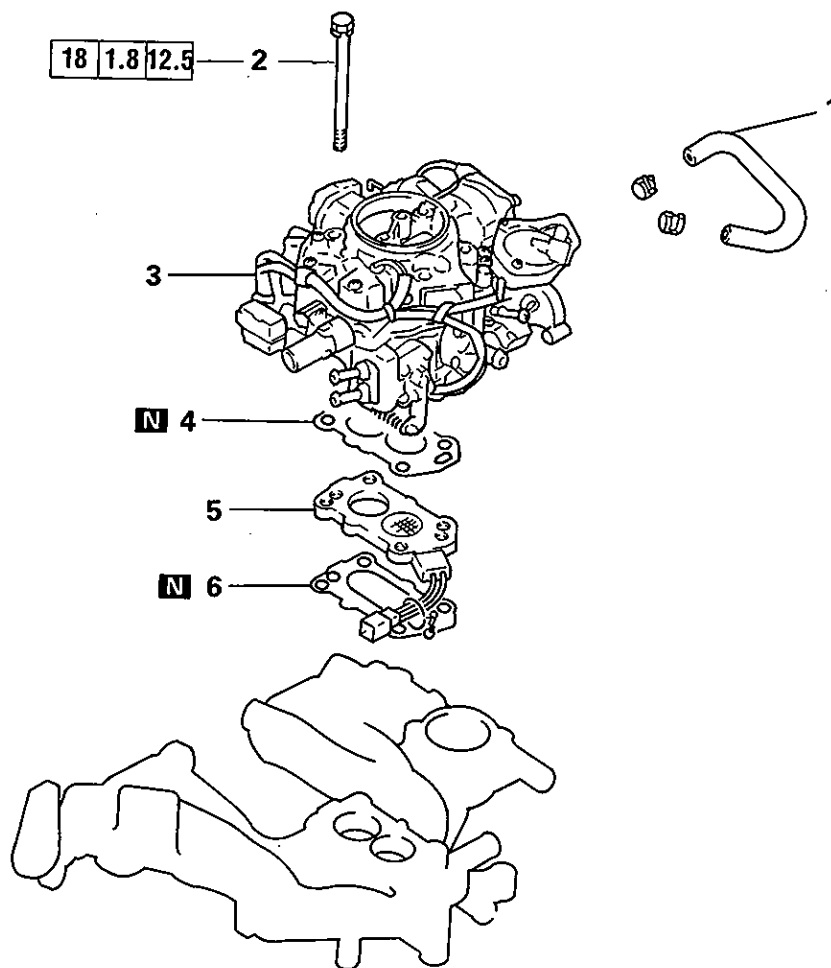
3. CARBURETOR ASSEMBLY**REMOVAL AND INSTALLATION****Removal steps**

1. Water hose
2. Bolt
3. Carburetor
4. Gasket
- ◇A◇ 5. Cold mixture heater (4G1 and 4G3 only)
6. Gasket

1FU0003

SERVICE POINT OF REMOVAL**◇A◇ COLD MIXTURE HEATER**

(1) Do not drop the cold mixture heater from a height of more than 30 cm (11.81 in.). Never use cold mixture heater which has been dropped.

INSPECTION**COLD MIXTURE HEATER**

Refer to Group 13A – CARBURETOR ASSEMBLY.

NOTES

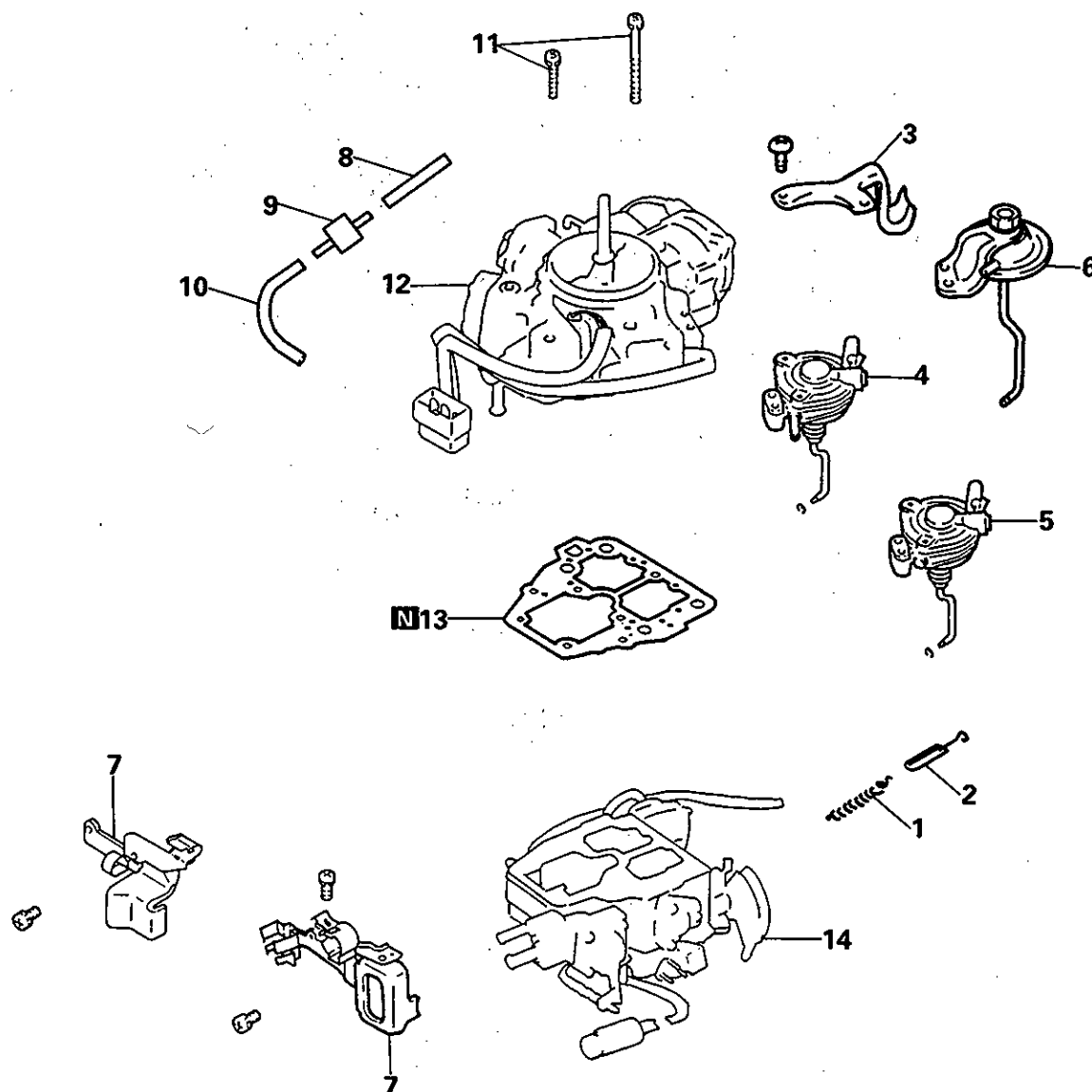
4. CARBURETOR**DISASSEMBLY AND REASSEMBLY****Disassembly steps**

1. Throttle-return spring
2. Rubber damper
3. Throttle-return spring bracket
4. Throttle opener/dash pot
5. Dash pot
6. Throttle opener
7. Bracket
8. Hose
9. Vacuum delay valve
10. Hose
11. Screw
12. Float chamber cover assembly
13. Float chamber cover gasket
14. Mixing body and throttle body assembly

◀A▶ ▶G▶

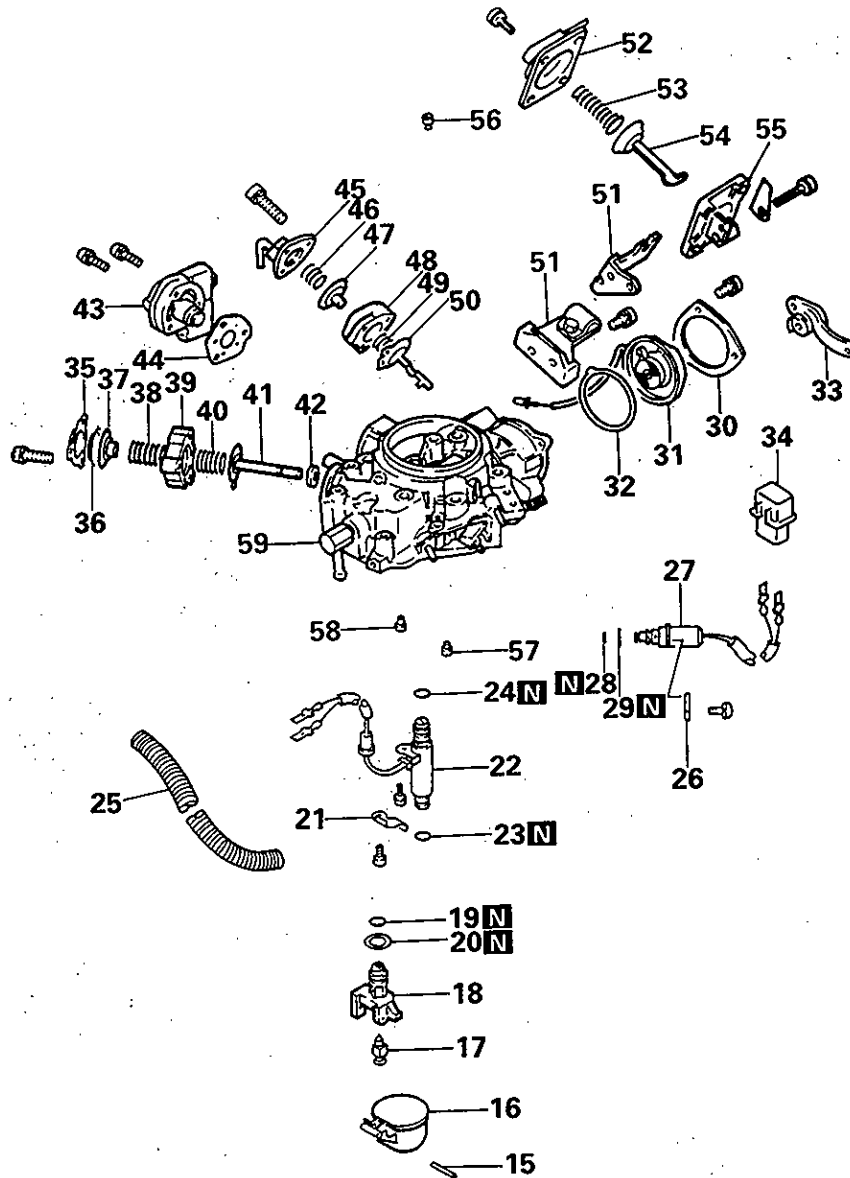

Disassembly steps

- | | | | |
|---------|-----------------------------|-----|------------------------------------|
| | 15. Pin | | 38. Spring |
| | 16. Float | | 39. Body |
| | 17. Needle valve | | 40. Spring |
| ◊B◊ | 18. Needle valve seat | | 41. Diaphragm |
| | 19. O-ring | | 42. Valve |
| | 20. Packing | | 43. Mixture control valve assembly |
| | 21. Retainer | | 44. Gasket |
| ◊C◊ ◊F◊ | 22. Feedback solenoid valve | | 45. Cover |
| | 23. O-ring | | 46. Spring |
| | 24. O-ring | | 47. Diaphragm |
| | 25. Tube | | 48. Body |
| | 26. Retainer | | 49. Spring |
| ◊D◊ ◊F◊ | 27. Slow cut solenoid valve | | 50. Diaphragm |
| | 28. O-ring | | 51. Bracket |
| | 29. O-ring | | 52. Cover |
| | 30. Plate | | 53. Spring |
| ◊E◊ ◊E◊ | 31. Bimetal assembly | | 54. Diaphragm |
| | 32. Packing | | 55. Body |
| ◊F◊ ◊D◊ | 33. Arm and pinion | ◊C◊ | 56. Main air jet (primary) |
| | 34. Connector | ◊C◊ | 57. Pilot jet (primary) |
| | 35. Cover | ◊C◊ | 58. Pilot jet (secondary) |
| | 36. Diaphragm | | 59. Float chamber cover |
| | 37. Spring seat | | |

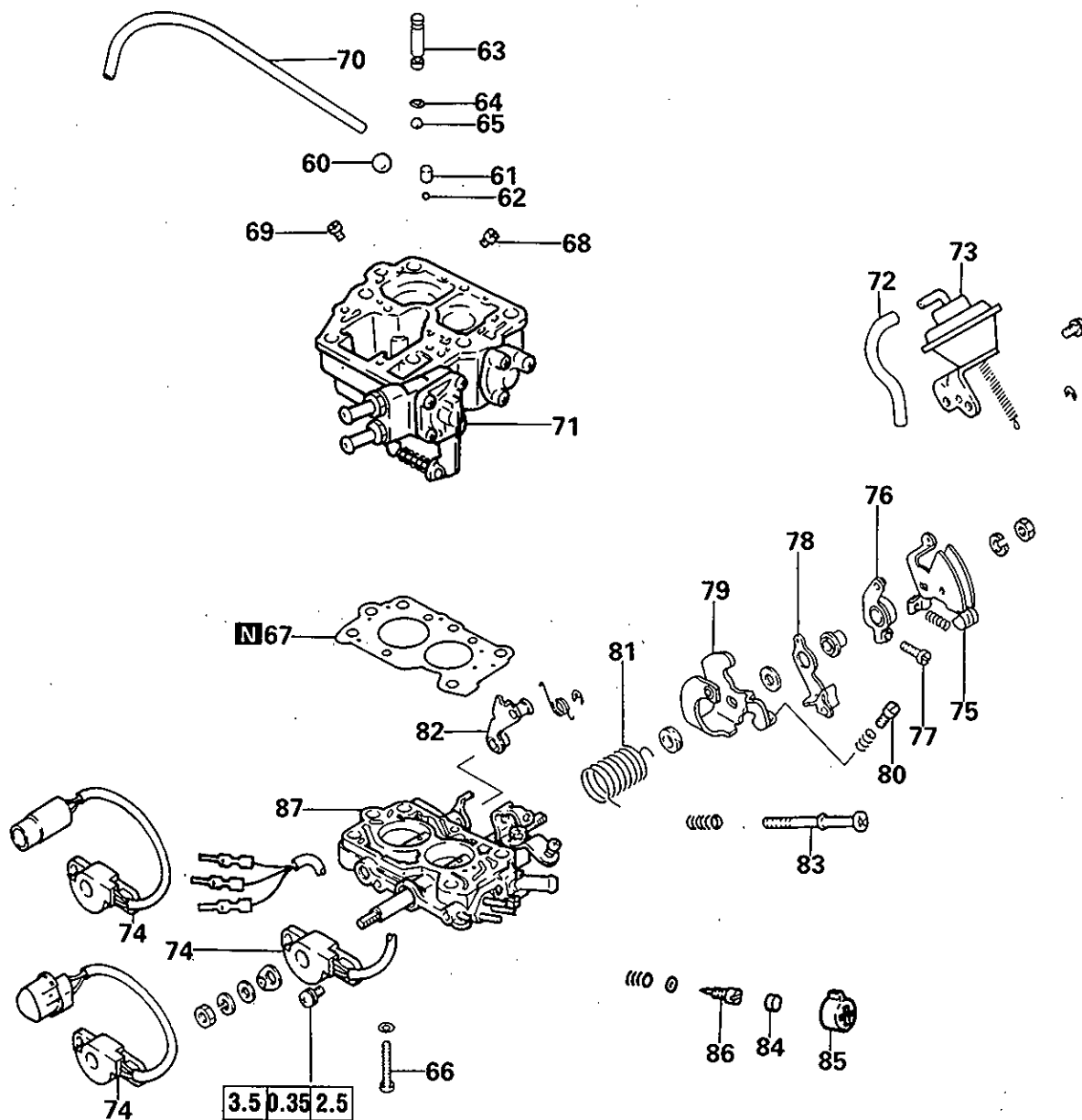

Disassembly steps

- ▶B▶ 60. Steel ball
- ▶B▶ 61. Weight
- ▶B▶ 62. Ball
- ◁G▶▶B▶ 63. Plug
- ◁G▶▶B▶ 64. O-ring
- ◁G▶▶B▶ 65. Ball
- ◁H▶▶ 66. Screw
- ▶ 67. Gasket
- ▶A▶▶ 68. Main jet (primary)
- ▶A▶▶▶ 69. Main jet (secondary)
- ▶ 70. Hose
- ▶ 71. Mixing body
- ▶ 72. Vacuum hose
- ▶ 73. Depression chamber
- ▶ 74. Throttle position sensor
- ▶ 75. Throttle lever
- ▶ 76. Cam follower
- ▶ 77. Fast idle adjusting screw
- ▶ 78. Free lever
- ▶ 79. Abutment plate
- ▶ 80. Idle speed adjusting screw-2
- ▶ 81. Spring
- ▶ 82. Secondary lever
- ▶ 83. Idle speed adjusting screw-1
- ◁I▶▶▶ 84. Concealment plug
- ▶ 85. Idle limiter cap
- ▶ 86. Mixture adjusting screw
- ▶ 87. Throttle body

SERVICE POINTS OF DISASSEMBLY

- Following parts must not be disassembled:
 - (1) Choke valve, choke shaft and automatic choke system
 - (2) Inner venturies
 - (3) Throttle valve and throttle shaft
 - (4) Fuel inlet nipple
 - (5) Enrichment, accelerator pump and auxiliary accelerator pump (AAP)
- When a cross-recessed screw is to be loosened, use a Phillips screwdriver of proper size for cross recess, as the screw is held tightly.
- When removing each jet, use a screwdriver which fits exact and work carefully so as not to damage the jet.

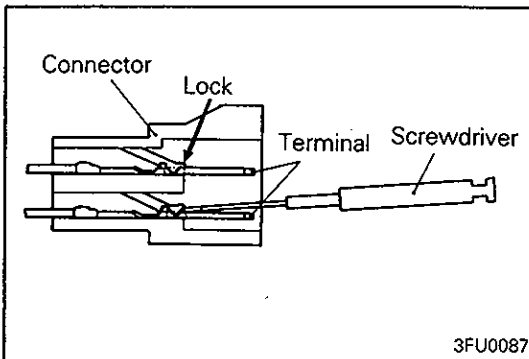
**HOW TO DISCONNECT THE TERMINAL FROM CONNECTOR SIX TERMINAL TYPE**

- (1) Push the lock by a screwdriver blade (or other thin and flat device) to remove the terminal from the back of the connector.

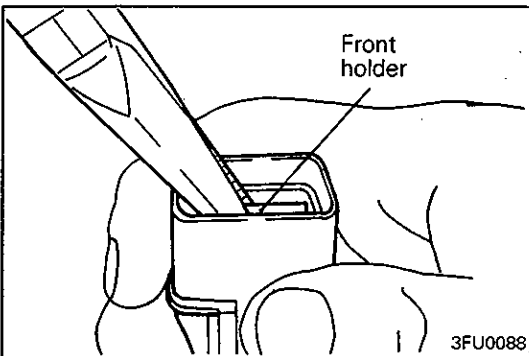
**EIGHT TERMINAL TYPE**

- (1) Remove the front holder using needle nose pliers.

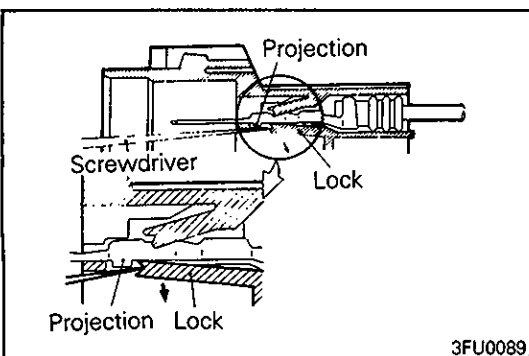

- (2) Push down the lock of the connector using a screwdriver [0.5 mm (0.020 in.) wide] as illustrated.

Caution

- Do not pry as the terminal projection could be damaged.

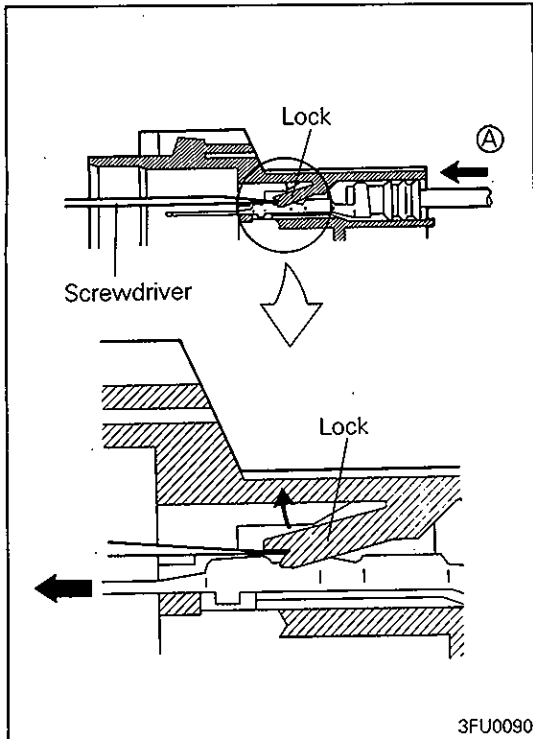

- (3) Insert a screwdriver along the terminal upper edge and pushing up the other lock, remove the terminal from the back of the connector as illustrated.

NOTE

Sliding the terminal in the direction of arrow (A) slightly will facilitate to push up the lock.

Caution

- Do not pry as the terminal and lock could be collapsed.

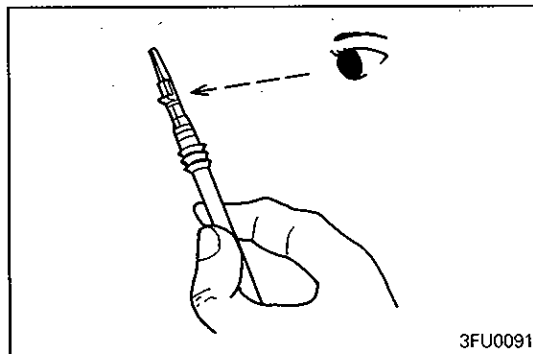

- (4) Check the removed terminal for abnormality. If abnormal, replace with a new one.

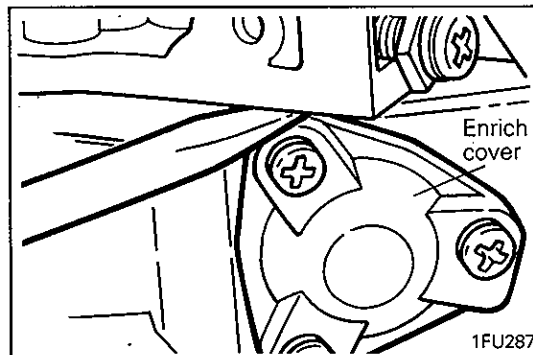

◇A◇ REMOVAL OF FLOAT CHAMBER COVER ASSEMBLY (SIX TERMINAL TYPE)

- (1) The cover is secured in position by gasket. Do not attempt to remove forcibly but insert the blade of a screwdriver between the enrich cover and float chamber cover and lightly pry it and gently lift up to remove the cover.

NOTE

Do not apply large force.

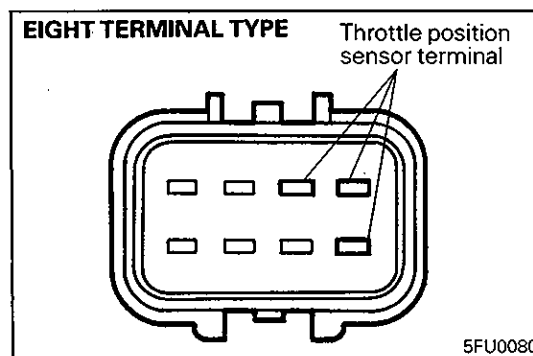

◇A◇ REMOVAL OF FLOAT CHAMBER COVER ASSEMBLY (EIGHT TERMINAL TYPE)

- (1) Remove the throttle position sensor terminals illustrated from the back of the connector.
For removal of the terminals, refer to HOW TO DISCONNECT THE TERMINAL FROM CONNECTOR (EIGHT TERMINAL TYPE).

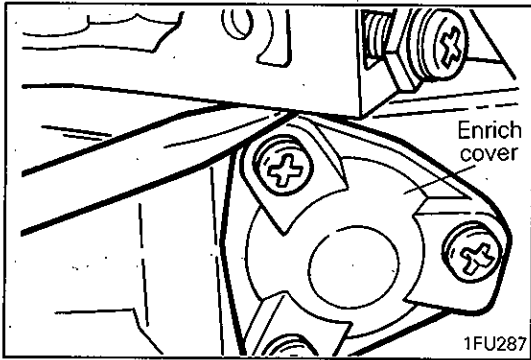

- (2) The cover is secured in position by gasket. Do not attempt to remove forcibly but insert the blade of a screwdriver between the enrich cover and float chamber cover and lightly pry it and gently lift up to remove the cover.

NOTE
Do not apply large force.

◁B▷ REMOVAL OF NEEDLE VALVE SEAT

- (1) Using flat tip screwdrivers at both edges, pry up and remove the needle valve seat.

NOTE
When doing so, use care not to damage the float chamber cover.

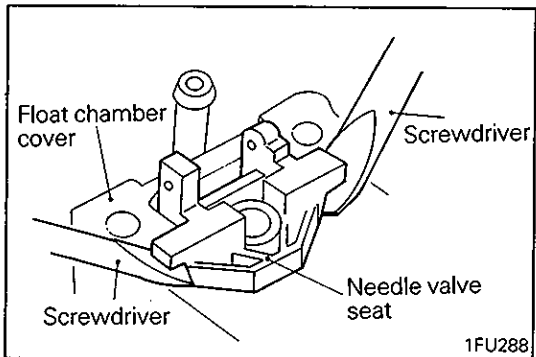

SIX TERMINAL TYPE

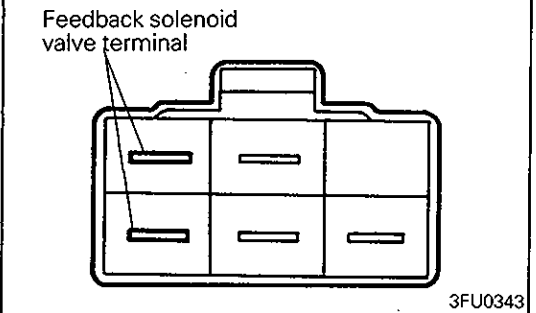

◁C▷ REMOVAL OF FEEDBACK SOLENOID VALVE

- (1) Remove the feedback solenoid valve terminals illustrated. For removal of the terminals, refer to HOW TO DISCONNECT THE TERMINAL FROM CONNECTOR.

EIGHT TERMINAL TYPE

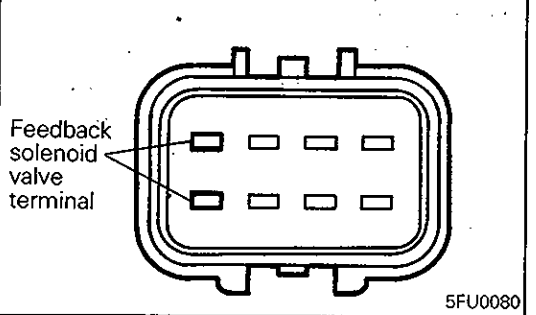

◁D▷ REMOVAL OF SLOW CUT SOLENOID VALVE

- (1) Remove the slow cut solenoid valve terminals illustrated. For removal of the terminals, refer to HOW TO DISCONNECT THE TERMINAL FROM CONNECTOR.

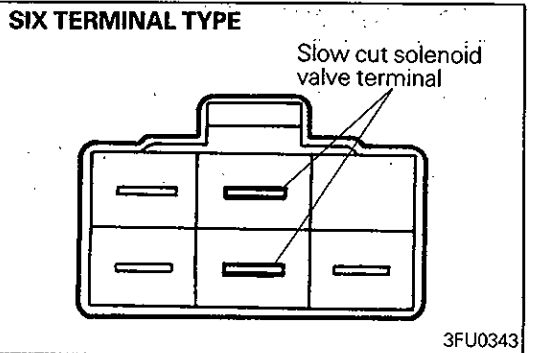

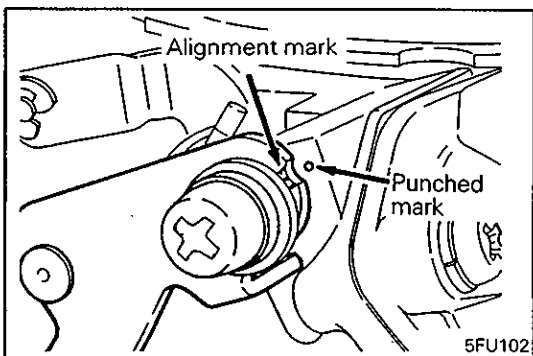
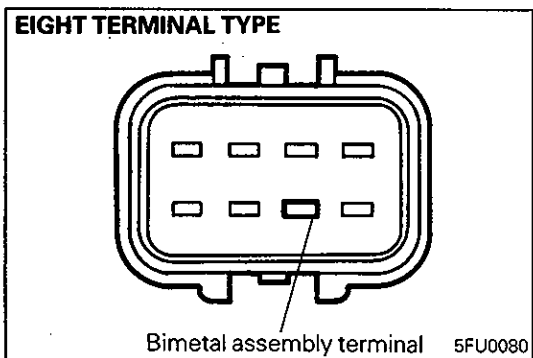
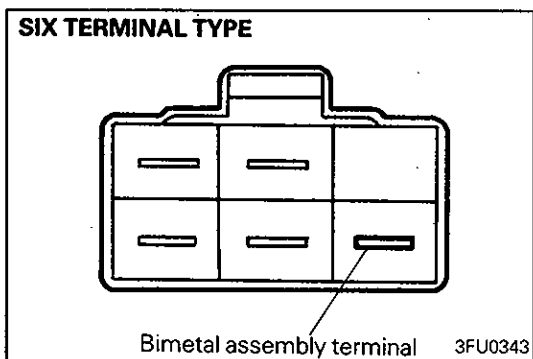
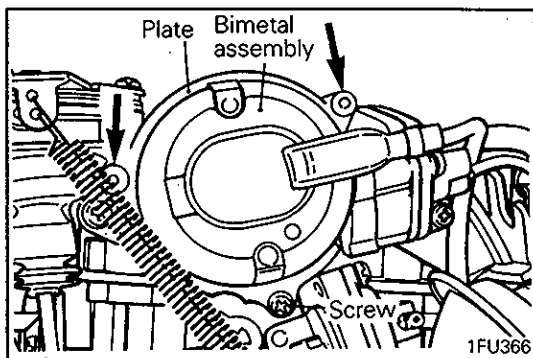
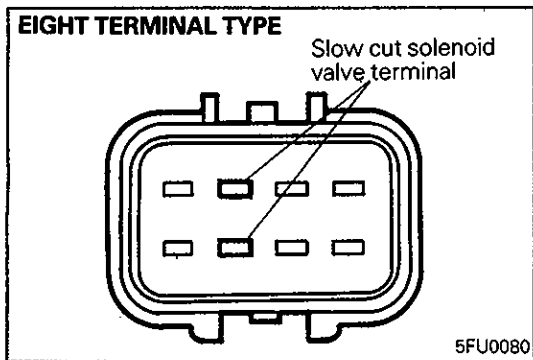

◁E▷ REMOVAL OF BIMETAL ASSEMBLY

- (1) Grind away the head of the two rivets of the bimetal assembly using a hand grinder or other tool. Remove the screw.
- (2) Remove the plate and the bimetal assembly.
- (3) Remove the remaining rivet bodies using a pin punch etc.

- (4) Remove the bimetal assembly terminal illustrated. For removal of the terminal, refer to HOW TO DISCONNECT THE TERMINAL FROM CONNECTOR.

◁F▷ REMOVAL OF ARM AND PINION

- (1) Before removing the arm and pinion, note the location of alignment marks shown in the illustration.

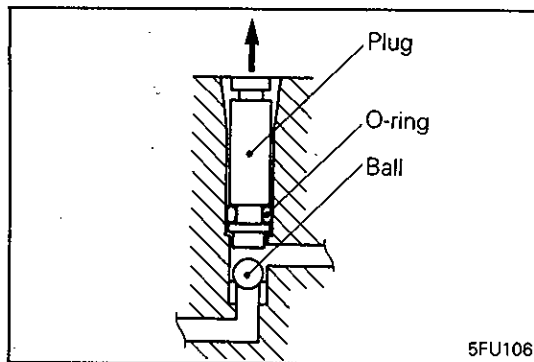

◁G▷ REMOVAL OF PLUG / O-RING / BALL

- (1) The plug has an O-ring at its tip and cannot be pulled out readily. Holding the plug with tweezers or the like and prying, pull out little by little.

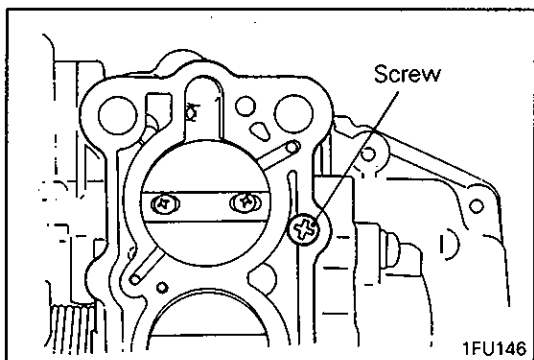

◁H▷ REMOVAL OF SCREW

- (1) Use care not to cause burrs to the screw head recesses as they could cause a gap between the manifold mounting surface.

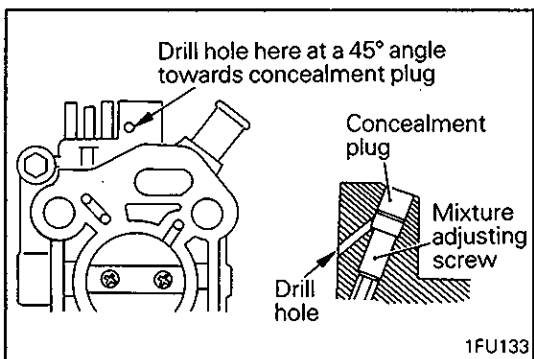

◁I▷ REMOVAL OF CONCEALMENT PLUG

- (1) Clamp carburetor in a vice with mixture adjusting screw facing up (protect gasket surface from vice jaws).
- (2) Drill a 2 mm (5/64 in.) pilot hole in the surrounding the mixture adjusting screw casting then redrill the hole to 3 mm (1/8 in.).
- (3) Insert a blunt punch into the hole and drive out plug.

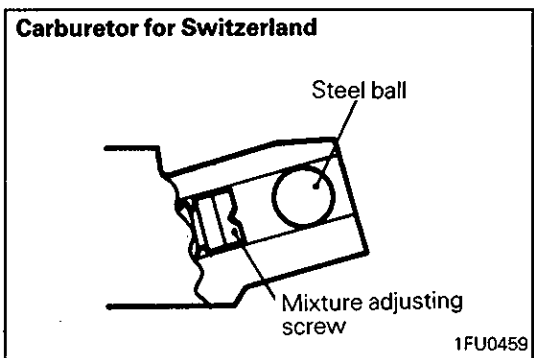

NOTE

Carburetor for Switzerland is press-fitted with steel ball type concealment plug which cannot be removed.

INSPECTION

GENERAL INSPECTION

Check the following and repair or replace parts if faulty.

- (1) Check fuel passages (jets) and air passages (jets or orifices) for clogging. If clogged, wash thoroughly with cleaning solvent or detergent and remove dirt by compressed air. Do not use wire or other metal pieces.

- (2) Check diaphragms, O-rings and springs for damage and cracks.
- (3) Check that needle valve operates lightly. If the valve is hard to operate or is binding, repair or replace. If there is overflow, poor valve to seat contact is suspected. Check thoroughly.
- (4) Check fuel inlet filter (located above the needle valve) for clogging and damage.
- (5) Check float operation. Check float and lever for deformation and damage and replace if necessary.
- (6) Check operation of throttle valve, choke valve and link. If they do not operate lightly, wash well and apply engine oil sparingly to their shaft.
- (7) Check float chamber cover and mixing body for damage and cracks.
- (8) For the inspection of the slow cut solenoid valve, bimetal and throttle position sensor, refer to Group 13 Fuel in the Work Shop Manual for the respective model.

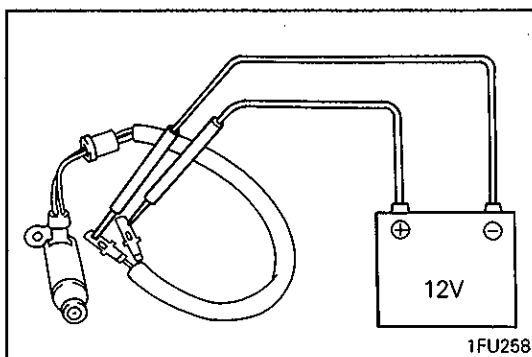

OPERATION CHECK OF FEEDBACK SOLENOID VALVE

- (1) Apply the battery voltage directly to the feedback solenoid valve terminal.
- (2) Check that a click is heard when the voltage is applied.

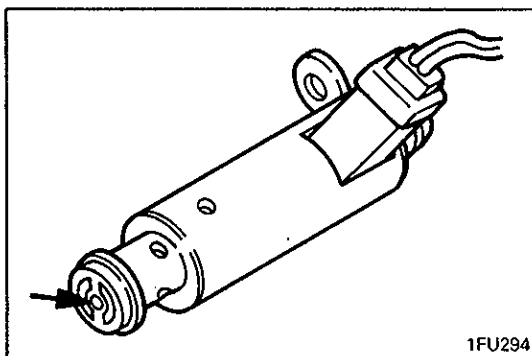

- (3) Check the jet for clogging.

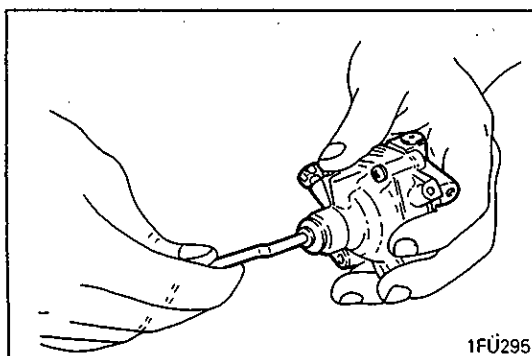

INSPECTION OF DASHPOT

- (1) Check that the dashpot operates correctly. Resistance must be felt when the dashpot rod is pulled. The dashpot rod must return quickly to its initial position when released. The diaphragm or the check valve is damaged if no resistance is felt when pulling the dashpot rod. If the rod returns slowly, the check valve is binding. In either case, replace the dashpot.

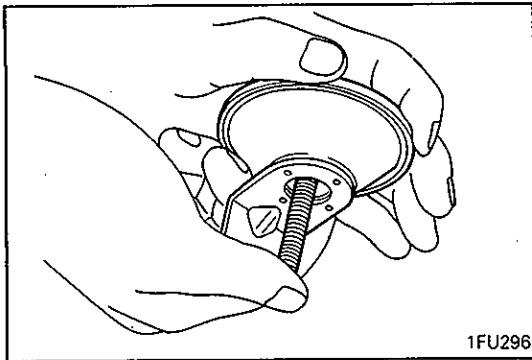

1FU296

INSPECTION OF DEPRESSION CHAMBER

- (1) Check the depression chamber diaphragm for damage. First, push up the rod fully and with the nipple closed tightly by a finger, release the rod. The diaphragm is okay if the rod does not return to its initial position while the nipple is closed. If the rod returns slowly or quickly, the diaphragm is broken. Then, replace the depression chamber.

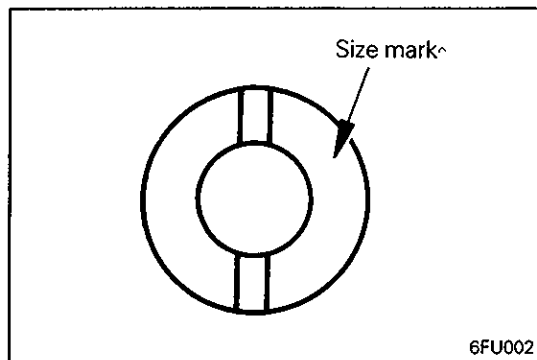

6FU002

SERVICE POINTS OF REASSEMBLY**▶▶ INSTALLATION OF MAIN JETS**

- (1) Install the jets at correct positions. Note the size symbol stamped on each jet.

NOTE

Refer to the table in GENERAL SPECIFICATIONS for the size symbols.

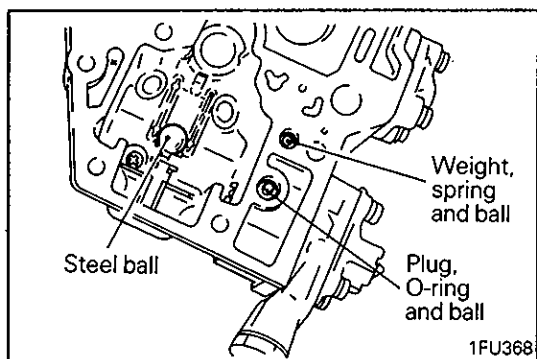

1FU368

▶▶ INSTALLATION OF BALL / O-RING / PLUG / BALL / WEIGHT / STEEL BALL

- (1) Install at correct positions in correct order.

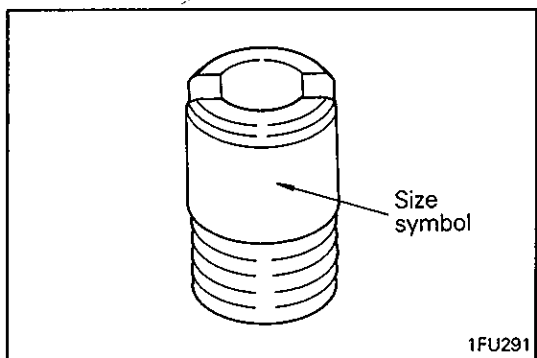

1FU291

▶▶ INSTALLATION OF JETS

- (1) Install the jets at correct positions. Note the size symbol stamped on each jet.

NOTE

Refer to the table in GENERAL SPECIFICATIONS for the size symbols.

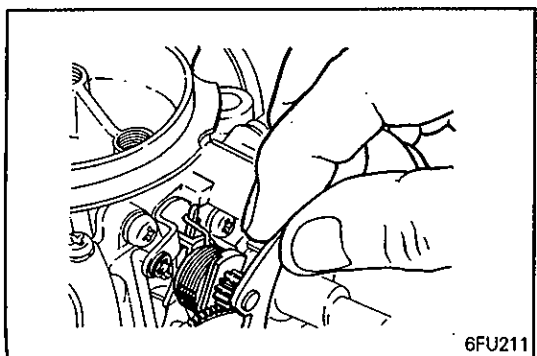

6FU211

▶▶ INSTALLATION OF ARM AND PINION

- (1) Install the strangler spring over the choke lever.

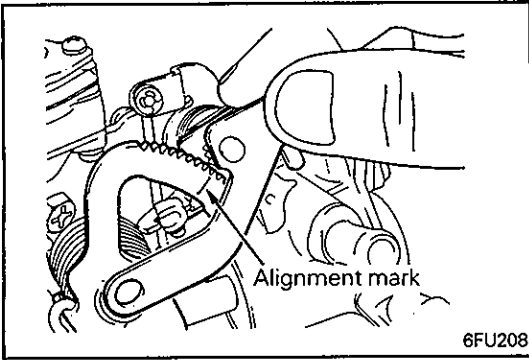

- (2) Install the arm and pinion, aligning the cam lever alignment mark with the choke pinion alignment mark.

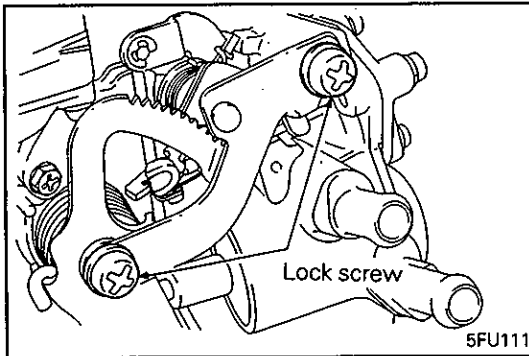

- (3) Tighten lock screws temporarily.

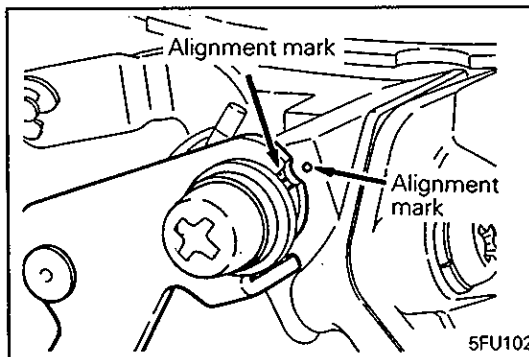

- (4) Slide the pinion vertically to set the alignment mark at position noted at time of disassembly.
- (5) Tighten lock screws.

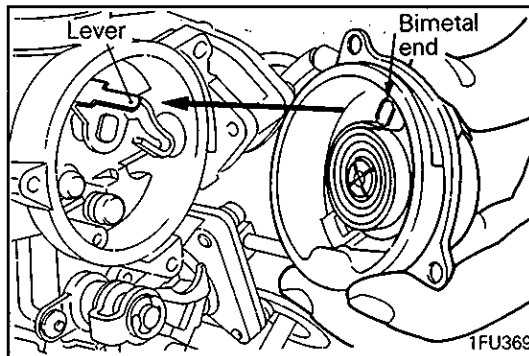

INSTALLATION OF BIMETAL ASSEMBLY

- (1) Fit the bimetal end over the choke valve lever.

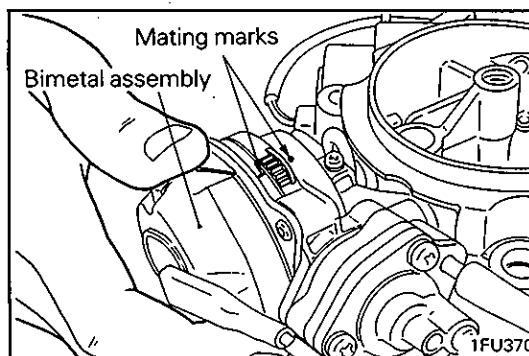

- (2) Install the plate and tighten the screw so that the bimetal assembly can be still turned by hand.
- (3) Align the mating marks.

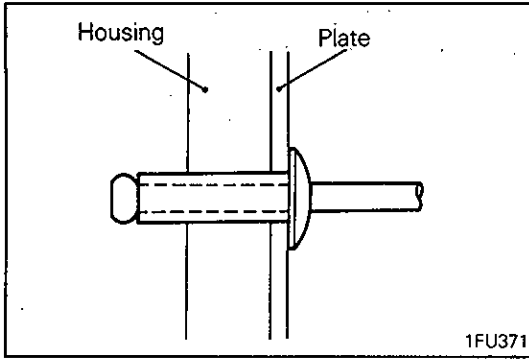

(4) Insert the rivets into the holes of plate and housing.

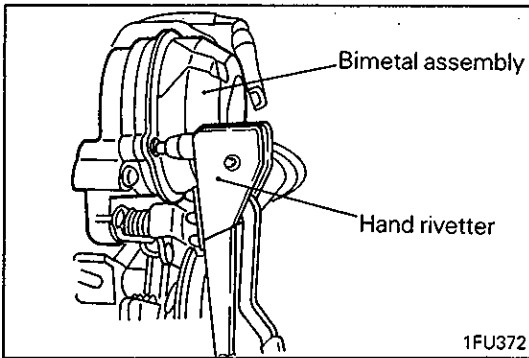

(5) While keeping the mating marks aligned, stake the rivets with a hand rivetter or similar tool.

(6) Tighten the screw firmly.

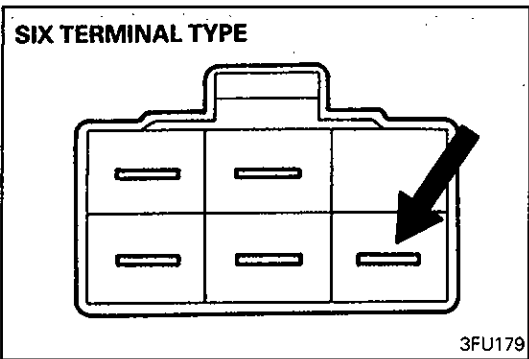

(7) Install terminal to the connector at correct position.

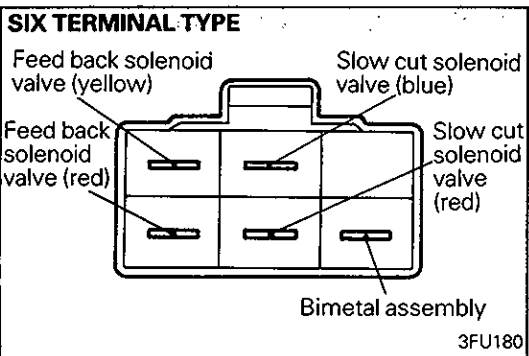

INSTALLATION OF SLOW CUT SOLENOID VALVE / FEED BACK SOLENOID VALVE

(1) Mount the terminals to the connector at correct positions.

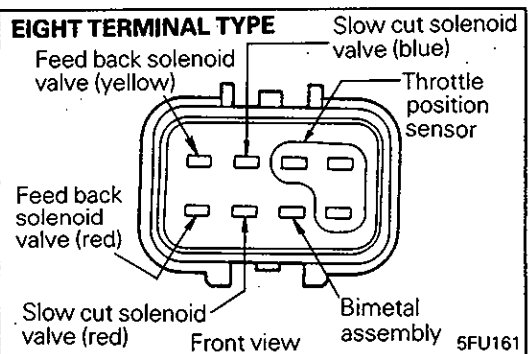

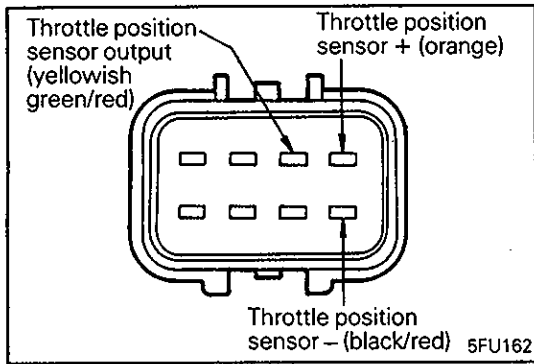

◆G◆ INSTALLATION OF FLOAT CHAMBER COVER ASSEMBLY (EIGHT TERMINAL TYPE)

- (1) After the float chamber cover has been installed, mount the three terminals of the throttle position sensor to the connector.

OPERATION OF SECONDARY THROTTLE VALVE

- (1) With the throttle valve fully open, operate the secondary throttle valve lever with a finger to check for play, poor operation or binding.
- (2) If it is hard to operate or is binding, clean and then apply a light coat of engine oil to the shaft.
- (3) If the play is excessive, replace the throttle body.

NOTES